

**STATE**  
**LIBRARY**  
**QUEENSLAND**



**STATE**  
**LIBRARY**  
QUEENSLAND

# Recording Studio Induction

October 2025



# Acknowledgement of country

We acknowledge Aboriginal and Torres Strait Islander peoples and their continuing connection to land and as custodians of stories for millennia. We respectfully acknowledge the land on which we all meet today and pay our respects to elders; past, present and emerging.



# Induction Summary

The Edge recording studio induction covers setup and operation of key audio equipment, like monitors, microphones, and preamps. Users learn essential steps for audio signal flow, power-up sequences, and DAW recording. It includes troubleshooting tips and foundational techniques for professional audio recording.

**The recording studio is a self-guided space. After the induction, equipment support is limited to encourage independent learning.**

Bookings are required to use the equipment, and you will be able to book with your SLQ account once you have completed the relevant induction.

You can book 2 sessions per week. Sessions are 2 or 4 hours long.

**Monday – Friday 12pm – 8pm**

**Saturday – Sunday 12pm - 5pm**

For more info and to book, head to <https://www.slq.qld.gov.au/visit/spaces/edge>

# Safety



## Duress Alarm

There is a duress alarm that is available if you require emergency medical or security assistance in the space. Please take note of the location of the duress alarm. **Located on to the left of the door as you walk in**

## No Access Behind The Studio Equipment

Please do not access the areas behind the studio equipment. There are a lot of power and audio cables that can be an electrical or trip hazard. Additionally, if something is accidentally unplugged, you may cause damage to the equipment and make the studio unavailable for the next patron booking.

## Other Hazards

You can request a staff member for any heavy/awkward lifting. Any electrical item that accesses a wall socket will need to be approved before you can plug it in. Ensure power points are not overloaded. If you have any trouble with equipment or furniture, please ask staff for assistance.

# Fire Evacuation

In the case of a fire evacuation, a siren will tone once to alert an evacuation, and a second time to alert urgency. Evacuate the studio and The Edge at once and follow the instructions of the fire warden.





Located on the wall next to the studio door.

# Air Conditioning

The AC switch helps minimise noise in your recording setup.

Set the AC switch to **LOW** during recording sessions to reduce unwanted hum or interference in your audio, especially when capturing sensitive sources.

At the end of your session, please turn the AC switch back to **HIGH** so fresh air in the space can be maximized.

# Studio Overview

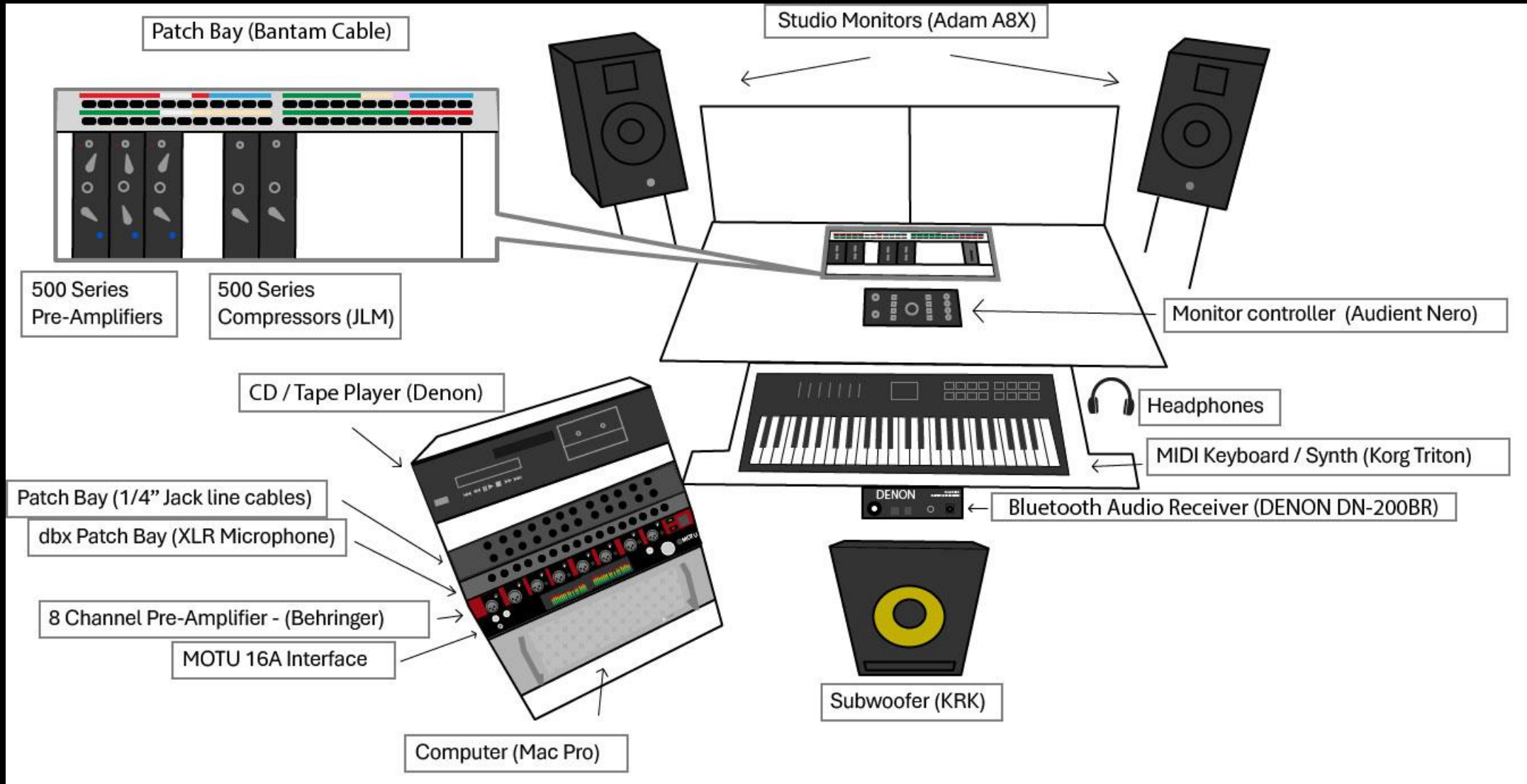

# Power On Procedure

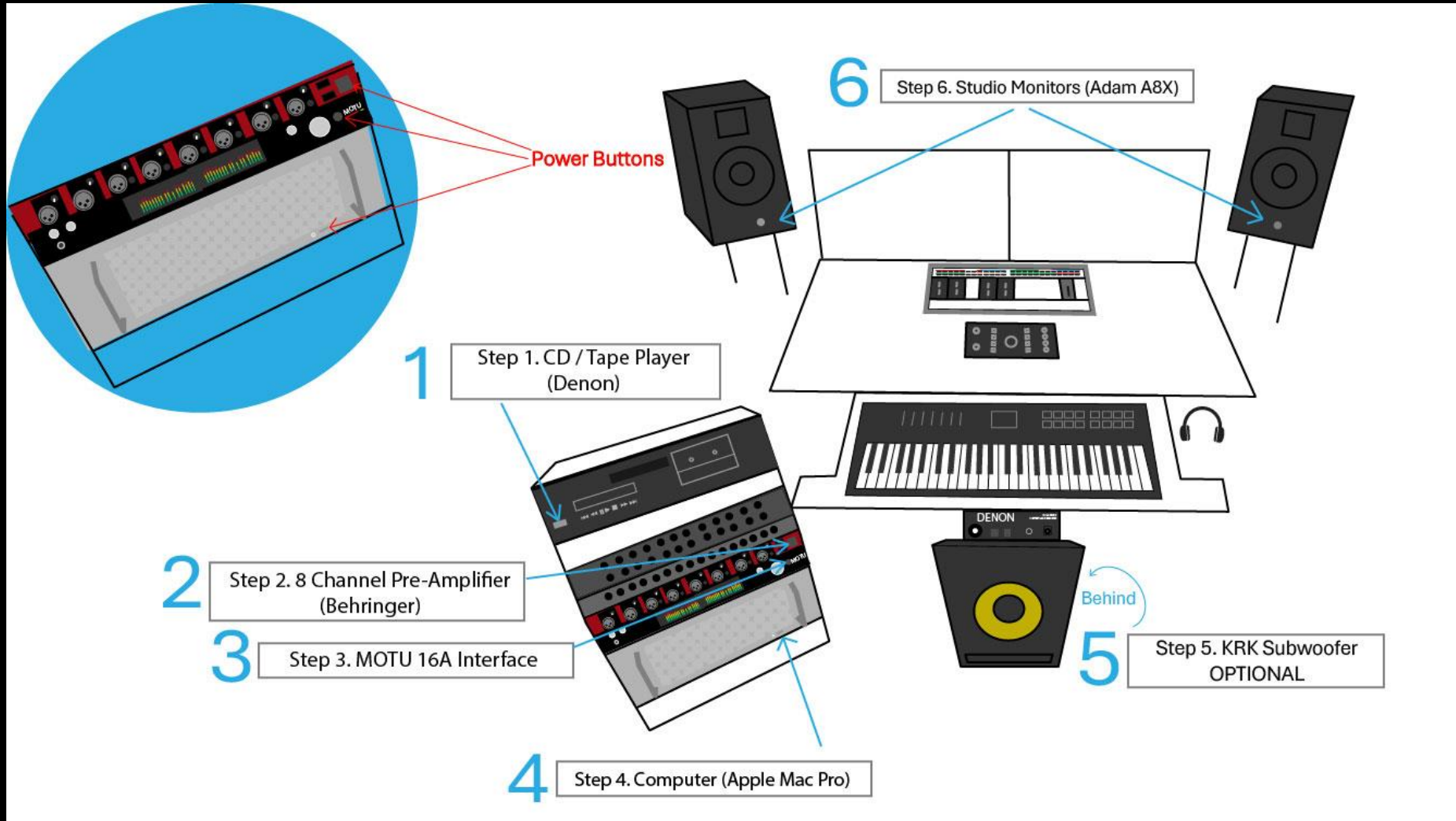

Power the equipment on in the order outlined below. Power off in the reverse order.

**NOTE: The studio equipment is turned on in this order to prevent damage and ensure all the hardware is communicating correctly**

# Signal Flow

Audio signal flow refers to the path that an audio signal takes from the initial sound source to the final output. When using a microphone to record audio in The Edge recording studio, the audio signal flow is as follows:

**Sound source:** This is the initial source of the audio, such as a voice or instrument.

**Microphone:** The microphone captures the sound waves produced by the sound source and converts them into an electrical signal.





**Pre-amp:** The pre-amp boosts the electrical signal from the microphone to a level that can be properly processed by other devices in the signal chain.

**Audio Interface:** The audio interface converts the analog electrical signal from the preamp into a digital signal that can be processed by a computer or other digital device.

**Computer:** The digital signal is then processed and recorded by a computer or other digital device and can be further edited or mixed as needed.

Understanding the audio signal flow is important for setting up and troubleshooting audio systems, as well as for understanding the effects of different processing devices on the final sound output.

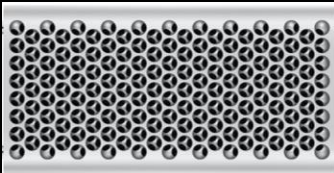
# Equipment Overview – Power on Procedure

Power on procedure	Unit	Image	Function
1	MOTU 16A Interface		Digital audio input/output converter
2	Denon CD/Tape Combi-Deck (Optional)		CD and Cassette input Cassette record output
3	Behringer ADA8200		8 Input, 8 Output preamp & ADAT
4	Apple Mac Pro (2020)		
5	KRK Subwoofer (Optional)		
6	Adam A8X Monitor Speakers		<i>*power down procedure is the same in reverse.</i>

# Signal Flow

Audio signal flow refers to the path that an audio signal takes from the initial sound source to the final output. When using a microphone to record audio in The Edge recording studio, the default audio signal flow is as follows:

## Input

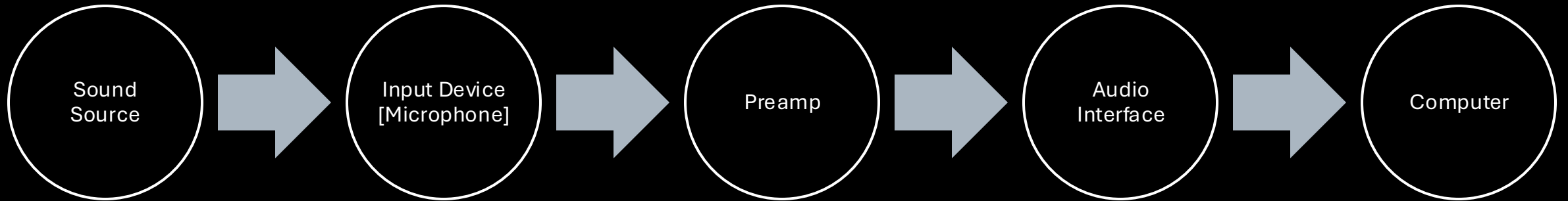

This is the initial source of the audio, such as a voice or instrument.

The microphone captures the sound waves produced by the sound source and converts them into an analogue electrical signal.

The pre-amp boosts the electrical signal from the microphone to a level that can be properly processed by other devices in the signal chain.

The interface takes all kinds of audio inputs and creates a simple digital information that communicates with the computer.

The digital signal is then processed and recorded by a computer or other digital device and can be further edited or mixed as needed.

# Signal Flow

## Output

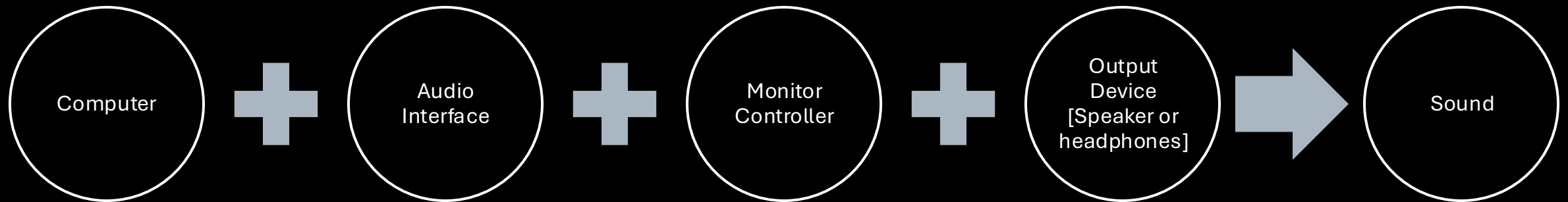

In playback the DAW or other sources sent to the audio interface

The interface takes all kinds of audio signal and converts them to an analogue audio signal.

The monitor controller allows you to select what output device you want to use and how much volume you want.

The speaker or headphones convert the analogue electrical signal into vibrations that the listener can hear.

# Monitor Controller

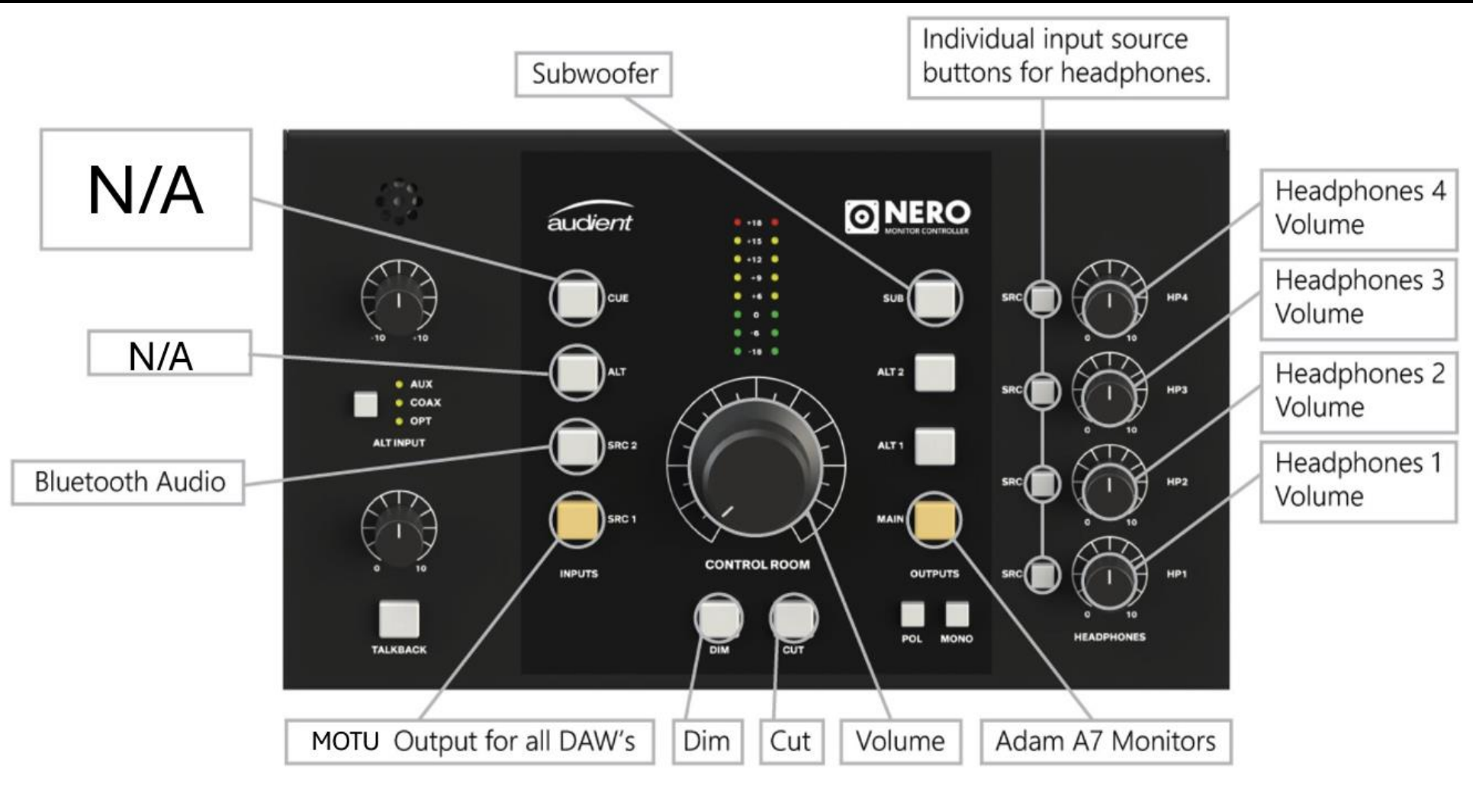

This diagram gives an overview of the mixer's controls as well as the inputs and outputs.

The default layout for recording using a DAW (Digital Audio Workstation) such as ProTools, Ableton or Logic has been selected in the diagram below.

# Dynamic & Condenser Mics



## Dynamic Microphones

Dynamic mics convert sound into electrical signals using a diaphragm connected to a coil within a magnetic field. This simple, durable design handles high sound levels well, making them ideal for loud sources like drums or amps, though they capture sound with less detail than condensers.

## Condenser Microphones

Condenser mics use a diaphragm placed close to a charged backplate, requiring 48v phantom power to create an electrical signal. This design is more sensitive and captures a broader frequency range, ideal for vocals and studio recordings where detail is essential.

## Key Differences

Dynamic mics excel with high-volume sources and rugged conditions, while condensers offer detailed, nuanced sound where capturing the full frequency spectrum is essential. This choice balances the need for durability and precision based on the recording setting and sound source.



# Specialised Mics



The Edge offers a selection of specialised microphones for unique recording needs, such as capturing high-detail vocals, instruments, or immersive audio.

These microphones are available in addition to those in the studio mic cabinet and can be requested at the front reception desk before your session.

For more information on available models, visit [The Edge Recording Studio page](#) or inquire with reception.



# Microphone Set Up



Grab your microphone and pop filter from the cabinet. We are using the Rode broadcaster.



Make sure you have the right mic clip that attaches the mic to the stand.



Screw the mic clip onto the stand - twisting the mic stand shaft is easier.



Attach the mic to the clip, using the nut.



Grab a mic lead from the wall



Plug in the female end to the mic.



Tighten the mic stand



Attach the pop filter.

# Microphone Pre-amp Selection

Choose which mic pre-amp to plug your mic into. All the mic pre-amp inputs are accessible via the XLR Patch Bay and the Behringer ADA820. The diagram below labels all the mic inputs.

**JLM Pre-Amp**  
Connect the male end of the mic lead to any XLR input labeled JLM 1-3



The ART P-16 will send its first three ports to the three corresponding JLM preamps on the desk, which will then send a signal to the MOTU 16A.



Any selection on the Behringer ADA8200 will suffice – each corresponds with their number on the MOTU 16A



# Behringer ADA8200 Pre-amp

Each input on the ADA8200 has its own gain knob, and the module has a Phantom Power switch that affects every input (green means Phantom Power is **off**, red means Phantom Power is **on**).

Each input can accept an XLR cable (microphones, some synths) or a ¼" line jack (instruments, also some synths).

You can indicate how much signal is being received from the light above each input and maintain it with the input's gain knob.



**48v (Phantom Power)**  
Condenser mics need  
48v Phantom Power  
from the preamp

# Pre-amp Settings

Adjust the pre-amp to suit your use case. The below diagrams and descriptions outline all the pre-amp controls

## JLM Mic Pre-Amps



### 48v (Phantom Power)

Condenser mics need 48v Phantom Power from the pre-amp to function.

### Input Gain

Set the gain level gradually, beginning at 20, to get a clear, undistorted sound.

### Output Trim

Fine-tune the gain with Output Trim for precise adjustments.

### Impedance

Adjusts resistance, affecting tone and signal flow between components.

### High Pass Filter

Cuts frequencies below 80 Hz to reduce bass and rumble.

### 20dB Pad

Reduces input level by 20 dB to prevent distortion with loud sources.

### Phase

Reverses audio signal polarity to fix phase issues in multi-mic setups.

### Direct Input

Allows instruments to connect directly to the pre-amp without a microphone.

# Sample Rates

When setting up a session in a DAW, choosing the right sample rate and bit depth is key to balancing quality and computer processing. The sample rate, measured in kHz, determines the number of samples recorded per second.

Common options include 44.1 kHz which is CD and standard streaming quality, and 48 kHz is ideal for professional audio and video. Higher rates like 96 kHz or 192 kHz are used in high-resolution music production, capturing more detail but requiring more processing.

Bit depth, such as 16-bit for CD quality and 24-bit or 32-bit for professional recording, affects dynamic range and detail, with higher depths offering greater detail and reducing noise. Selecting the right sample rate and bit depth optimises quality for the intended use and aligns with system capabilities.

**A good balance of audio quality and computer processing for music production is 48k / 24bit.**

# Playback engine and latency

## **Playback Engine**

In The Edge studio, the MOTU 16A is the playback engine for DAWs; ensure 16A is selected.

## **Latency**

Latency, a delay when audio is processed and output, can affect timing during recording. Adjusting buffer size can reduce latency; 128–256 samples is ideal for balancing low delay and stable audio playback without glitches.

Changing the buffer size can help reduce latency when recording. A smaller buffer size means less delay but a higher chance of audio dropouts or glitches, while a larger buffer size means more delay but a lower chance of audio dropouts or glitches. Adjusting the buffer size can help find the best balance between low latency and stable audio playback.

In general, a buffer size of 128 or 256 samples is a good starting point for most recording situations, as this provides a good balance between low latency and stable audio playback without dropouts or glitches.

See the below image for how to change the PLAYBACK ENGINE and BUFFER SIZE in ProTools, Ableton, and Logic

# Audio track overview

### ProTools Audio Track Layout

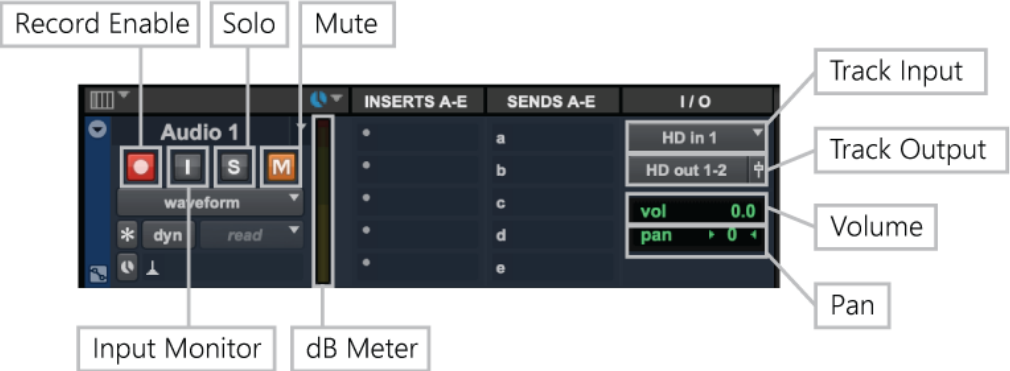

### Logic Audio Track Layout

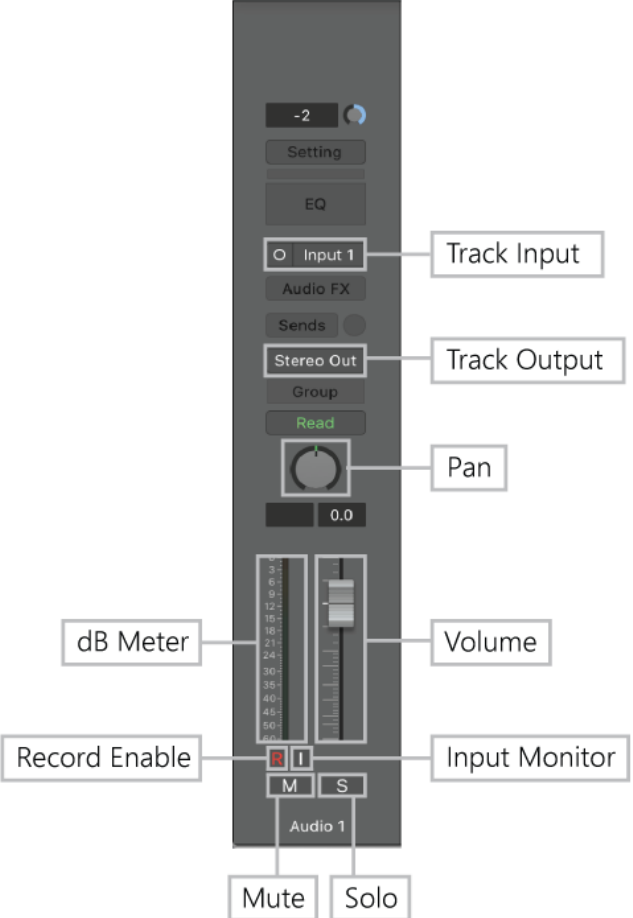

### Ableton Audio Track Layout

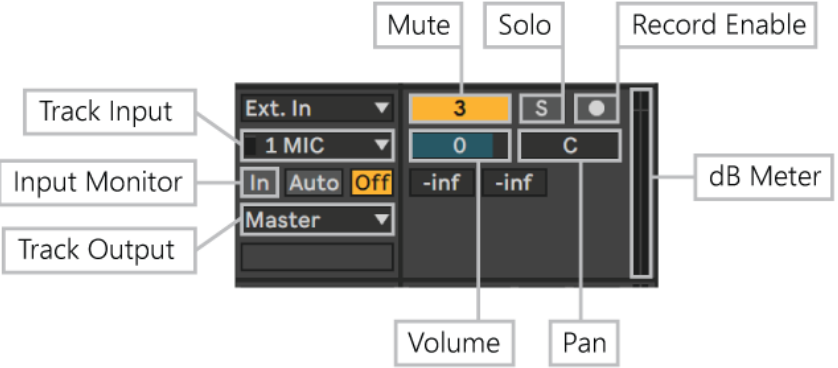

# Choosing audio track input

In your DAW, select the audio track input to correlate with the pre-amp your microphone is connected to.

Pre-amp - DAW Input

JLM 1 - Input 1

JLM 2 - Input 2

JLM 3 - Input 3

ADA8200 – BEHRINGER 1

ADA8200 – BEHRINGER 2

ADA8200 – BEHRINGER 3

ADA8200 – BEHRINGER 4

ADA8200 – BEHRINGER 5

ADA8200 – BEHRINGER 6

ADA8200 – BEHRINGER 7

ADA8200 – BEHRINGER 8

# Setting gain level

You can use the dB meter in your DAW's audio tracks to help you set your gain level on your pre-amp. Setting the gain while the sound source is at its loudest ensures a clean recording with enough headroom to accommodate sudden spikes or peaks in the signal, preventing distortion and unwanted artifacts.

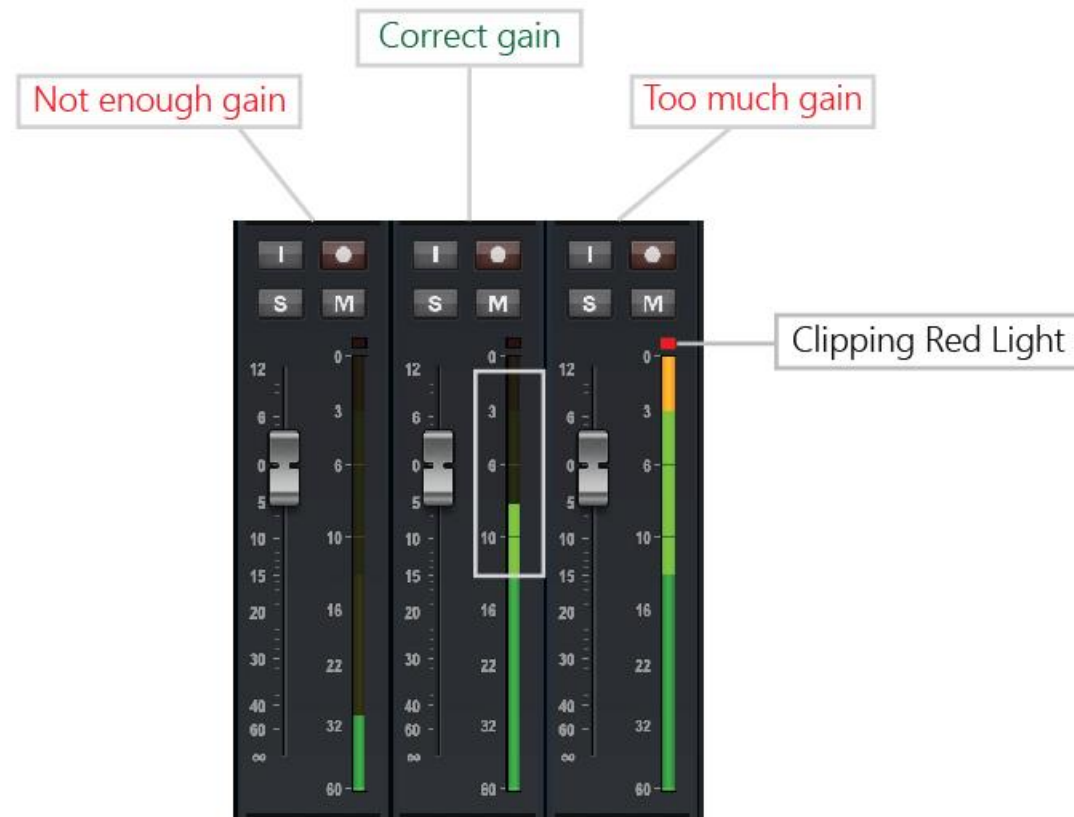

# DAW settings – ProTools

To create a mono audio track in ProTools go to the menu and select - **Track > New**

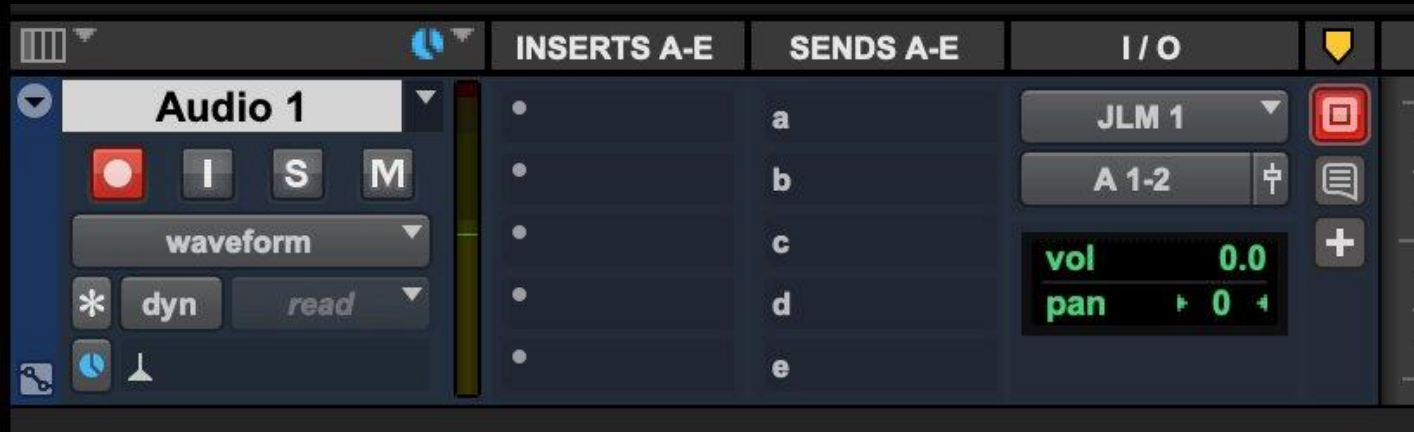

JLM 1 Selected for input using JLM 1 preamp

A 1-2 for output

# DAW settings – Logic Pro X

To create a mono audio track in Logic, go to the menu and select - **Track > New Tracks**

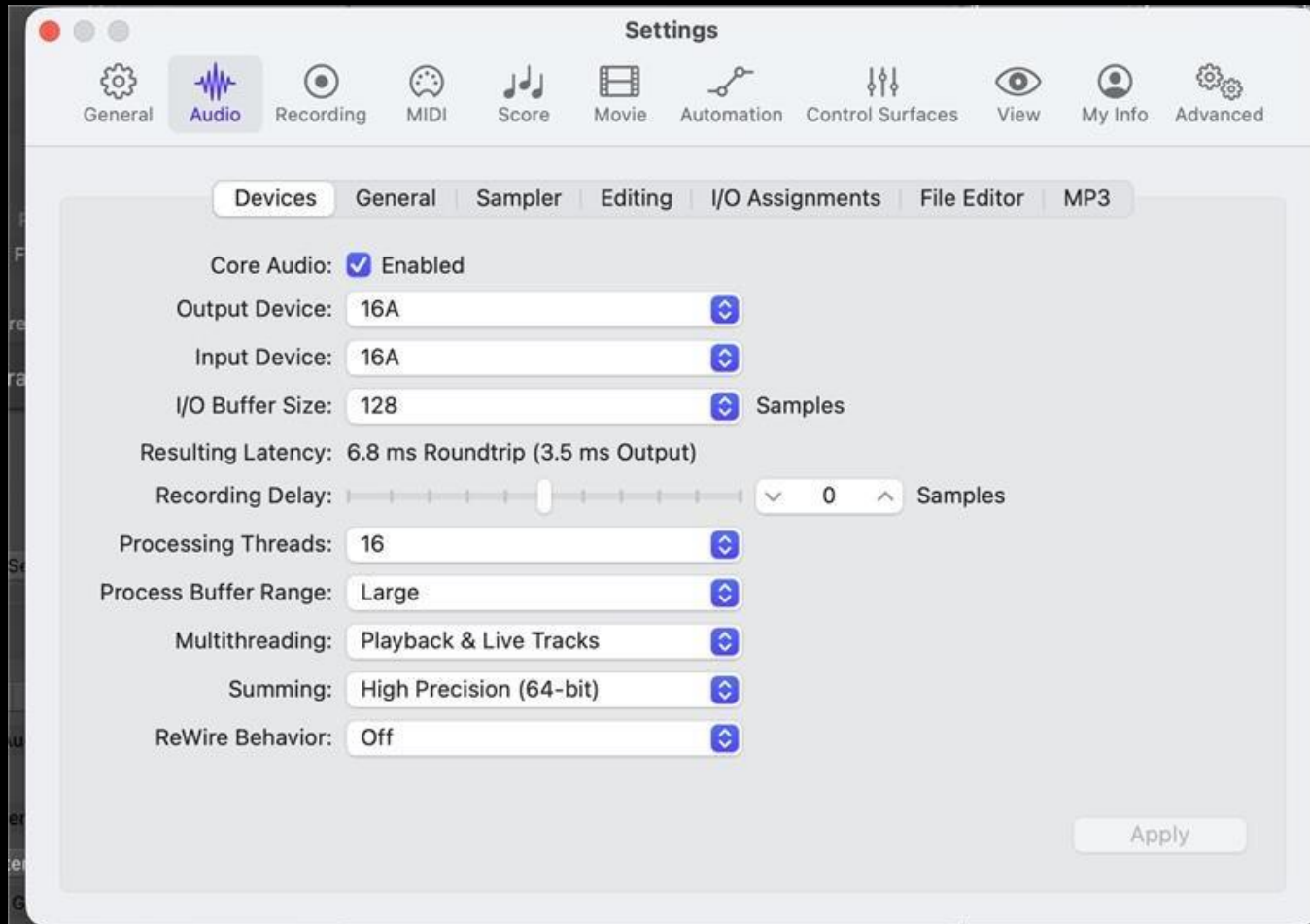

**Core Audio enabled**

**Input & Output set to 16A**

**128** buffer – Buffer size means lower delay between playing notes and hearing them

# DAW settings – Ableton Live Suite 12

To create a mono audio track in Ableton, go to the menu and select - **Create > Insert Audio Track**.

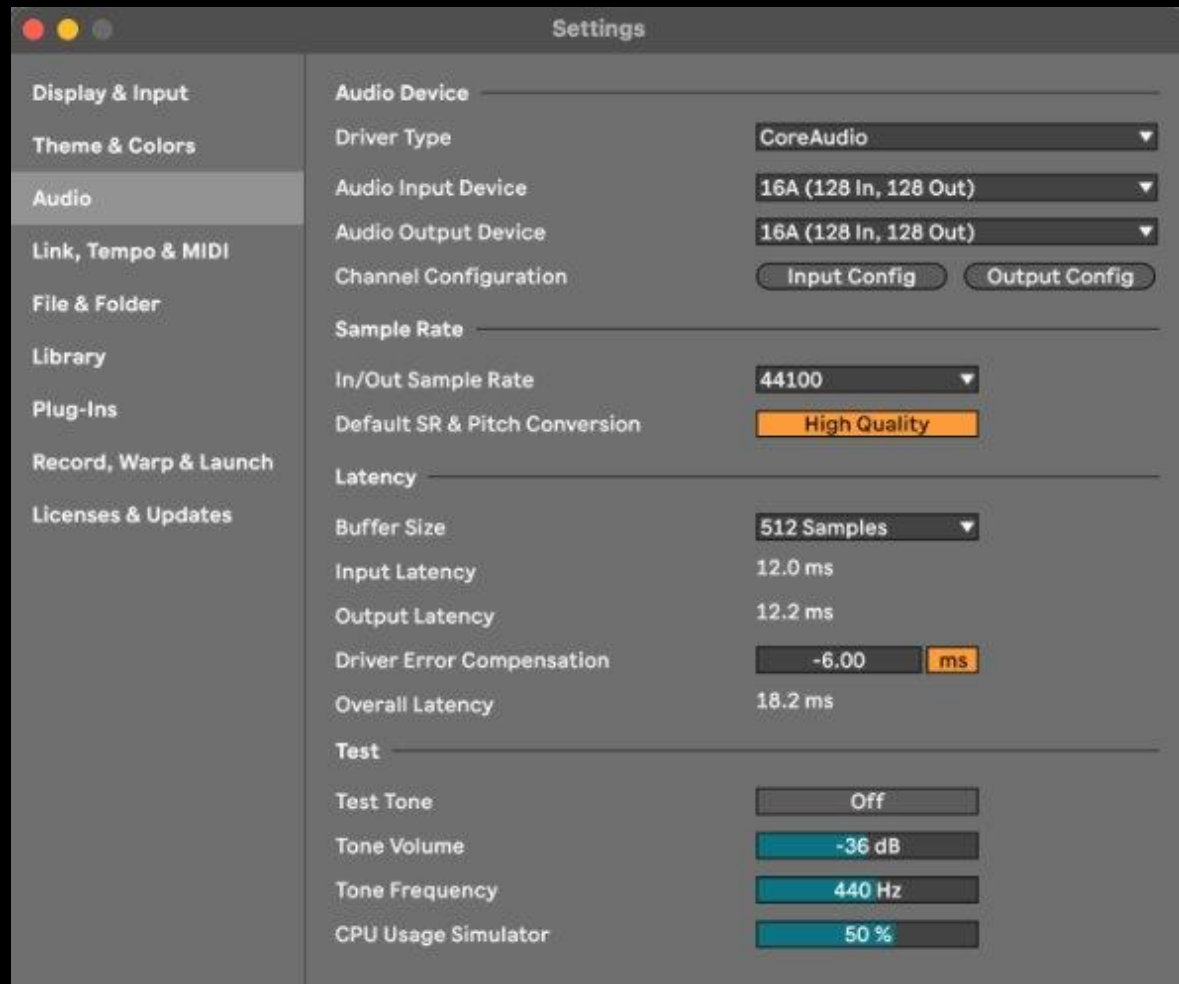

Use CoreAudio for driver  
16A for input and output

512 buffer size means higher delay between playing a note and hearing one

# Recording check list

Follow this checklist to set up and record audio in your chosen DAW effectively. **Ensure monitor volume is down and use headphones to avoid feedback.**

- **Create Session in DAW:** Open your DAW (Pro Tools, Logic, Ableton, etc.) and create a new session with your desired sample rate and bit depth.
- **Connect Microphone to Preamp:** Connect your microphone to your chosen preamp. If using a condenser mic, ensure 48v phantom power is engaged.
- **Create New Track:** Add an audio track for recording in your session.
- **Select Input:** Choose the correct input for your mic or instrument.
- **Enable Track for Recording:** Record-enable the track you'll be recording on.
- **Set Gain on Preamp:** Adjust the preamp gain for a clear, undistorted signal.
- **Record Enable Session:** Make sure the session is ready to record.
- **Hit Record:** Press record to begin capturing audio.

# Bantam patch bay

A bantam patch bay routes audio between studio equipment, with a half-normalised setup automatically directing signals from the top row (outputs) to the bottom row (inputs) without a patch cable.

**Default Signal Path:** In this setup, a preamp output on the top row will automatically connect to an HD Native converter input on the bottom row.

**Flexible Rerouting:** Insert a patch cable to interrupt the default path and redirect the signal as needed.

This configuration keeps hardware connections organised and allows easy rerouting for different recording setups.



# Bantam patch bay

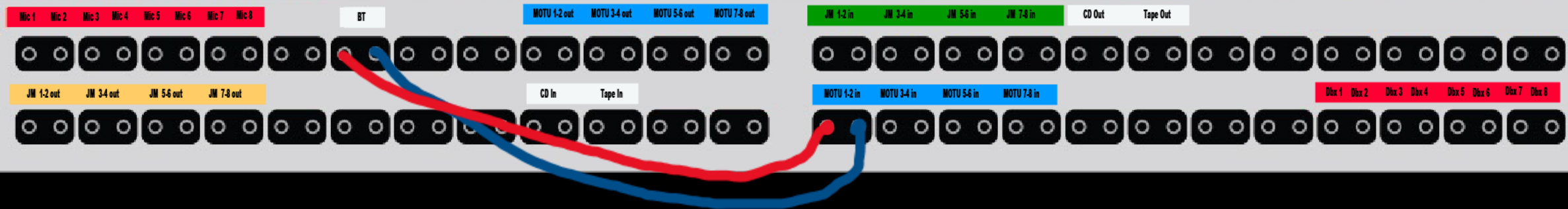

## Example: Routing Bluetooth Output to MOTU Input

**Patch the Signal:** Use a patch cable to connect the output from the Denon Bluetooth (top row - "BT") to the input of the MOTU Audio Interface (bottom row "MOTU 1-2in/3-4in/5-6in/7-8in")

**Set DAW Input:** In your DAW, set the track's input to *Input 1* to receive the signal processed from the compressor.

This manual patching method allows you to insert the tools like the Bluetooth Receiver or the JLM Compressor into the signal path.

# Analogue synthesisers

The Moog Grandmother and Behringer MonoPoly synthesisers are connected to inputs 7 and 8 on the Behringer ADA8200. To record, power on the synth, select the correct input channel in your DAW (BEHRINGER 7 for MOOG, and BEHRINGER 8 for MonoPoly), and adjust the preamp gain for a clear signal.



POWER (Back side of unit)



**MOOG GRANDMOTHER**

ADA8200 Input 7



POWER  
(Front side of unit)

**BEHRINGER MONOPOLY**

ADA8200 Input 8

# CD/Cassette "Combi-Deck"

The DENON CD/Cassette Combi-Deck can record CDs and cassette tapes as an input into the DAW and can be recorded onto as an output from the DAW.

To utilise the Combi-Deck, you can patch the "CD Out" or "Tape Out" spaces into a "MOTU \*x-y\* in" and use it as a line input. Use "CD in" or "Tape in" into "MOTU \*x-y\* Out" to use it an output.



# Exporting / bouncing audio

## **Exporting Audio / Bouncing Audio**

Exporting / Bouncing in a DAW converts your session into an audio file, typically a stereo WAV or MP3 format, which is ready for playback outside the DAW. WAV files are high-quality, uncompressed formats ideal for professional use, while MP3s are compressed, smaller in size, and more suitable for online sharing or casual listening.

## **Saving the Session**

Saving the session preserves all DAW settings, tracks, edits, plugins, and configurations as a project file. This allows you to reopen and edit the project later, but it is not a playable audio file outside the DAW environment.

## **Key Difference**

Exporting creates a standalone audio file of your mix, while saving a session retains your full project for further editing.

# Disk and usage

All sessions must be saved to the drive named scratch disk.

## File privacy & backup

Scratch disk is a temporary, shared storage.

- Make sure to back up the session folder not just the session file. This ensures you back all the audio files and settings of your session.
- Scratch drive will be wiped and reformatted when full
- Other users can see and read/write/delete your files
- Please take your files with you on an USB drive or stick.
- Scratch disk is deleted every 12-months.

# Frequently asked questions

- Can we bring other people in to record that haven't been inducted? Yes, as long as an inducted SLQ member books the spaces you can bring up to 6 people into The Edge recording studio without overcrowding, and up to 10 total people at absolute maximum.
- Can I bring drums in to record? Yes
- Can I plug my laptop in and record directly to my own computer? No not at this stage, however we are currently looking into this option for the future.
- When will I be able to book after the induction? Please allow 48 hours for your induction to be processed.
- Can I use the recording studio if I have gone over my weekly booking limit? Yes, if the studio is available, you can ask The Edge reception for access to the studio. They will check you have completed your induction and will let you into the space.
- Is the room completely soundproof? Unfortunately not, the room impedes sound very well, but doesn't completely nullify it outside of the room. Likewise, loud noise can bleed into the room.

## THANKS FOR ATTENDING

---

Please complete our survey that will be sent out via  
Eventbrite.

Tag us on socials @statelibraryqld

Contact us on [appliedcreativity@slq.qld.gov.au](mailto:appliedcreativity@slq.qld.gov.au)



**STATE**  
**LIBRARY**  
QUEENSLAND



[slq.qld.gov.au](http://slq.qld.gov.au)